

1. 适用安全规格 Application This

规范应用于树脂成型后SMD类型安全标准认证的电容器类型:CK 型号
Specification is applied to following resin molding SMD type safety standard recognized ceramic capacitor Type: CK

CK 型是安全标准认证陶瓷电容器类X1, Y1。
The type is safety standard certified ceramic capacitor of Class X1, Y1.

2. 安全规格认证标准 Approval standard and recognized number

安规认证机构 Safety Standard	标准NO Standard No.	证书NO Recognition No.	额定电压 Rated Voltage
UL	UL60384-14	E221839	X1: 250/300/400/500VAC Y1: 250/300/400/500VAC
ENEC (DEMKO)	EN 60384-14:2013/A1:2016, EN 60384-14:2013	ENEC-04533	
CQC	GB/T 6346.14-2015	CQC20001273585	
CB	IEC60384-14:2013/AMD1:2016, IEC60384-14:2013	US-33608-UL	
KC	KC60384-1(2015-09), KC60384-14(2015-09)	SU03040-23001	Y1: 250VAC

3. 使用温度范围 Operating temperature range

-40~+125°C

4. 品名构成说明 Part number configuration

例.	<u>CK</u>	<u>E</u>	<u>102</u>	<u>M</u>	<u>2HA</u>	<u>80</u>	<u>A</u>	<u>A</u>	<u>R</u>	<u>C</u>
ex.	产品类别 Type name	温度特性 Temperature characteristic	公称静电容 量 Capacitance tolerance	静电容量公 差 Capacitance code	额定电压 Rated voltage	尺寸代码 Size code	脚型代码 Foot type code	脚距代码 Pitch code	包装方式 Packing method	内部代码 Internal code

4.1 产品类别 Type name

代码 Code	类别 Category
CK	Y1 SMD 陶瓷电容器 Y1 SMD Ceramic Capacitors

4.2 温度特性 Temperature characteristic

代码 Code	温度特性 Temperature characteristic
S	SL
B	Y5P
E	Y5U
F	Y5V

4.3 公称静电容量 Capacitance

公称静电容量采用三位数表示法.前面2位数字为有效数值,第三位数字表示0的个数.
The first two digits denote significant figures : the last digit denotes the multiplier of in pF.

例:) 代表: 102
ex.) In case of 10 X 10²= 1000pF

4.4 静电容量公差 Capacitance code

代码code	许容差 Tolerance
K	±10%
M	±20%

4.5 额定电压 Rated voltage

代码code	额定电压 Rated voltage
2EA	X1,Y1:250V~
2FA	X1,Y1:300V~
2GA	X1,Y1:400V~
2HA	X1,Y1:500V~

4.6 尺寸代码 Size code

代码code	本体尺寸 Body case size (L X W)
80	8.0×6.0

4.7 脚型代码 Foot type code

代码code	脚型 Foot type
A	外折弯 Outer bend

4.8 脚距代码 Pitch code

代码code	L1(mm)	L2(mm)
A	9.9±0.5	11.4±0.5
B	8.6±0.5	10.0±0.5

4.9 包装方式代码 Packing style code

代码code	包装方式 Packing type
R	卷轴编带

4.10 内部代码 Internal code

内部管理码 Internal management code

具体的详细规格请参考[规格和测试方法]

Please confirm detailed specification on [Specification and test method].

5 标志 Marking

- (1) 类别名称 Type name : CK
- (2) 公称静电容量 Nominal capacitance : 3位数表示法 3 digit system 例 ex 222=2200pF
- (3) 许容差 Allowable tolerance : K=±10%, M=±20%
- (4) 额定电压 Rated Voltage : X1Y1: 250/300/400/500V~
- (5) 公司商标 Company name code : **WMEC**
- (6) 内部追溯码 Internal traceability code : 29003A

例 EX :

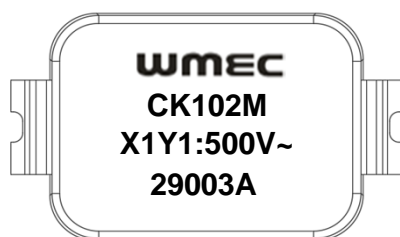

6. 零件号码列表 Part number list

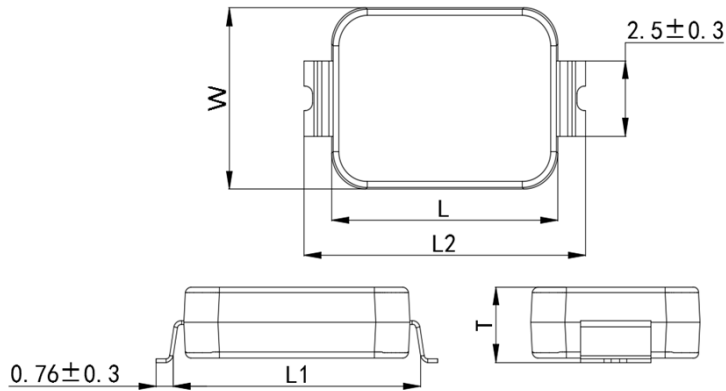

T.C. 温度特性	Cap. (Pf) 容量	Cap. Tol. 公差	Wanming Part Number 万明料号	Dimension(mm) 尺寸			Size code 尺寸代码	Pack qty (pcs) 包装数量
				L	W	Tmax		
SL	10	±10%	CKS100K***80A*RC	8.0±0.5	6.0±0.5	2.6	80	2500
SL	15	±10%	CKS150K***80A*RC	8.0±0.5	6.0±0.5	2.6	80	2500
SL	22	±10%	CKS220K***80A*RC	8.0±0.5	6.0±0.5	2.6	80	2500
SL	33	±10%	CKS330K***80A*RC	8.0±0.5	6.0±0.5	2.6	80	2500
SL	47	±10%	CKS470K***80A*RC	8.0±0.5	6.0±0.5	2.6	80	2500
SL	68	±10%	CKS680K***80A*RC	8.0±0.5	6.0±0.5	2.6	80	2500
B	82	±10%	CKB820K***80A*RC	8.0±0.5	6.0±0.5	2.6	80	2500
B	100	±10%	CKB101K***80A*RC	8.0±0.5	6.0±0.5	2.6	80	2500
B	150	±10%	CKB151K***80A*RC	8.0±0.5	6.0±0.5	2.6	80	2500
B	220	±10%	CKB221K***80A*RC	8.0±0.5	6.0±0.5	2.6	80	2500
B	330	±10%	CKB331K***80A*RC	8.0±0.5	6.0±0.5	2.6	80	2500
B	470	±10%	CKB471K***80A*RC	8.0±0.5	6.0±0.5	2.6	80	2500
B	680	±10%	CKB681K***80A*RC	8.0±0.5	6.0±0.5	2.6	80	2500
E	680	±20%	CKE681M***80A*RC	8.0±0.5	6.0±0.5	2.6	80	2500
E	1000	±20%	CKE102M***80A*RC	8.0±0.5	6.0±0.5	2.6	80	2500
F	1500	±20%	CKF152M***80A*RC	8.0±0.5	6.0±0.5	2.6	80	2500
F	2200	±20%	CKF222M***80A*RC	8.0±0.5	6.0±0.5	2.6	80	2500

常规SMD-Y1.CAP 容值范围及温度特性区分: (Unit:pF)

Conventional SMD-Y1.CAP capacity range and temperature characteristic distinction

T.C	10	15	22	33	47	68	82	100	150	220	330	470	680	1000	1500	2200
SL	■	■	■	■	■	■										
Y5P							■	■	■	■	■	■	■			
Y5U													■	■		
Y5V															■	■
UR	250/300/400/500V.ac															
工作温度范围 Operating temperature range	-40°C to 125°C															
气候类别 Climate category	40/ 125/ 21															

7. 规格及测试方法 Specifications and test methods

7.1 测试标准条件:a.温度:15~35℃ b.湿度:45~75% c.大气压:86~106千帕

Standard test conditions: a. Temperature: 15~35 °C b. Humidity: 45~75% c. Atmospheric pressure: 86~106 kPa;

(如有争议时或顾客要求时,采用:a.温度25±2℃ b.湿度:60~70% 大气压:86~106千帕)

(In case of disputes or customer requirements, use: a. temperature 25 ± 2 °C b. humidity: 60~70% atmospheric pressure: 86~106 kPa)

7.2 规格 Specifications

NO.	项目 Item	规格 Specification	测试方法 Test method												
1	工作温度 Operating Temperature	-40~+125°C													
2	外观 Appearance	外观无可见损伤 No defects or abnormalities	目视检查外观. Visual inspection.												
3	尺寸 Dimensions	尺寸符合规格要求 Within the specified dimension.	尺寸使用游标卡尺测量. Using calipers and micrometers.												
4	绝缘强度 Dielectric strength	无可见损伤 No defects or abnormalities.	用AC4000V(r.m.s.)测定60s, (充电/放电电流≤50 mA) The capacitor shall not be damage when AC4000V(r.m.s.) is applied between the terminations for 60 s.(Charge/Discharge current≤50mA)												
5	绝缘电阻(IR) Insulation Resistance(I.R.)	6000 M Min	绝缘电阻应以DC500±50V测定60±5秒, 应用于电容器的电压通过电阻1 MΩ。 The insulation resistance shall be measured with DC500 ± 50V within 60 ± 5 s of charging.The voltage should be applied to the capacitor through a resistor of 1MΩ .												
6	静电容量 Capacitance	符合规定许容差以内 Within the specified tolerance.	在温度25±2℃,以频率1±0.2KHz(SL特性:1±0.2MHz),电压1V±0.2rms测定. Capacitance/Q/D.F. shall be measured at 25°C with the frequency of 1±0.2kHz (SL char. 1±0.2MHz) and a voltage of AC1±0.2V(r.m.s.).												
7	Q 损耗系数(D.F) Q Dissipation Factor (D.F.)	SL : Q : ≥ 1000 (C ≥ 30pF) Q : > 400+20C (C < 30pF) C : 静电容量 Nominal Capacitance (pF) B,E(DF) : 2.5% max. F(DF) : 5.0% max.													
8	温度特性 Capacitance Temperature Characteristics	温度系数 Temp. Coefficient SL: +350 to -1000 ppm/°C (温度范围 Temp. Range:-20~85°C) 容量变化率 Cap. Change B:±10% E: +20/-55% F: +30/-80% (温度范围 Temp. Range:-25~85°C)	<p>每一步都应进行电容测量。</p> <p>•对B,E,F特性的预处理: 在150+0/-10℃的温度下进行热处理, 60±5分钟, 然后在室温下放置24±2h。</p> <p>The capacitance measurement shall be made at each step in table.</p> <p>•Pretreatment for B,E,F char:Perform the heat treatment at 150+0/-10 °C for 60±5 min and then let sit for 24±2 h at *room condition.</p> <table border="1" style="margin-left: auto; margin-right: auto;"> <thead> <tr> <th>Step</th> <th>1</th> <th>2</th> <th>3</th> <th>4</th> <th>5</th> </tr> </thead> <tbody> <tr> <td>Temp.(°C)</td> <td>25±2</td> <td>-25±2</td> <td>25±2</td> <td>85±2</td> <td>25±2</td> </tr> </tbody> </table>	Step	1	2	3	4	5	Temp.(°C)	25±2	-25±2	25±2	85±2	25±2
Step	1	2	3	4	5										
Temp.(°C)	25±2	-25±2	25±2	85±2	25±2										

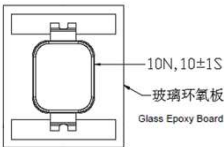
NO.	项目 Item		规格 Specification	测试方法 Test method
9	耐振性 Vibration resistance	外观 Appearance	无破缺,开裂等异常 No marked defect.	将电容器焊接到测试夹具A(玻璃环氧板)上, 该电容器受一个总振幅为1.5mm的简单谐波的影响, 频率在10和55Hz的近似极限之间一致。频率范围, 从10到55Hz, 返回到10Hz, 应在大约1分钟内遍历。该运动应在每三个相互垂直的方向(共6h)中应用一个2小时的周期。 Solder the capacitor to the Test Jig A (glass epoxy board) shown in "Complement of test method". The capacitor shall be subjected to a simple harmonic motion having a total amplitude of 1.5mm, the frequency being varied uniformly between the approximate limits of 10 and 55Hz. The frequency range, from 10 to 55Hz and return to 10Hz, shall be traversed in approximately 1 min. This motion shall be applied for a period of 2 h in each of 3 mutually perpendicular directions (total of 6h).
		静电容量变化率 Capacitance change	符合规定许容差以内 Within the specified tolerance.	
		损耗系数 Q D.F.	参见项目7. Pass the item No.7.	
10	引脚焊锡性 Solderability of termination		引脚上须有75%以上面积被新焊锡覆盖 75% of the terminations are to be soldered .	将电容器浸在乙醇溶液和松香(占比重25%的松香)中沉浸2±0.5 s.焊接温度.:245±5°C Immerse the capacitor in the solution of ethanol and rosin (25% rosin in weight proportion). Immerse in solder solution for 2±0.5s. Temp. of solder : 245±5°C
11	焊锡耐热性 (回流) Soldering effect (Reflow)	外观 Appearance	无破缺,开裂等异常 No marked defects.	将电容器预热到150 - 180度。 回流温度:230°C min (最大温度:260°C) 回流时间:30±10 s. 回流次数:4次。 放置室温 24±2 h再测量 •在样品温度下降后再进行回流焊。 •B,E,F温度特性的预处理: 电容器应储存在150 + 0/-10°C 1 h, 施加AC4000V 60s的电压, 然后放在室内条件24±2 h, 再进行初步测量。 Preheat the capacitor at 150 to 180°C for 90±30s. Reflow temp. : 230°C min. (Max. temp. : 260°C) Reflow time : 30±10s. Reflow number of times : 4 times Let sit at *room condition for 24±2 h, then measure. • The next reflow process should be done after the temperature of the sample has dropped to room temperature. • Pretreatment for B,E,F char:Capacitor should be stored at 150+0/-10°C for 1 h, and apply the AC4000V(r.m.s.) 60s then placed at *room condition for 24±2 h before initial measurements.
		静电容量变化率 Capacitance change	±10%以内 Within ±10%	
		I.R.	1000MΩ Min	
		绝缘强度 Dielectric strength	参见项目4. Pass the item No.4.	
12	引脚的粘合强度 Adhesive strength of termination		引脚没有偏移或者其他缺陷 No removal of the terminations or other defects should occur.	将电容器焊接到测试夹具A(玻璃环氧板)上, 然后向箭头方向施加10N力。 Solder the capacitor to the Test Jig A (glass epoxy board) shown in "Complement of Test method" . Then apply 10N force in the direction of the arrow. 

NO	项目 Item	规格 Specification	测试方法 Test method															
13	外观 Appearance	无破缺,开裂等异常 No marked defect.	温度循环 (5次) Perform the 5 cycles according to the 4 heat treatments listed the following table. <table border="1" data-bbox="922 322 1474 562"> <thead> <tr> <th>步骤 Step</th> <th>1</th> <th>2</th> <th>3</th> <th>4</th> </tr> </thead> <tbody> <tr> <td>温度 Templ(°C)</td> <td>-40±3</td> <td>室温 Room Temp.</td> <td>125±3</td> <td>室温 Room Temp.</td> </tr> <tr> <td>时间 Time(min.)</td> <td>30±3</td> <td>2~3</td> <td>30±3</td> <td>2~3</td> </tr> </tbody> </table> 在室内环境放置24±2h再进行测量。 Let sit for 24±2 h at *room condition, then measure. <ul style="list-style-type: none"> •B,E,F温度特性的预处理: 电容器应储存在150 + 0/-10° C 1 h, 施加AC4000V 60s 的电压, 然后放在室内条件24±2 h, 再进行初步测量。 •Pretreatment for B,E,F char:Capacitor should be stored at 150+0/-10° C for 1 h, and apply the AC4000V(r.m.s.) 60s then placed at *room condition for 24±2 h before initial measurements. 	步骤 Step	1	2	3	4	温度 Templ(°C)	-40±3	室温 Room Temp.	125±3	室温 Room Temp.	时间 Time(min.)	30±3	2~3	30±3	2~3
	步骤 Step	1		2	3	4												
	温度 Templ(°C)	-40±3		室温 Room Temp.	125±3	室温 Room Temp.												
	时间 Time(min.)	30±3		2~3	30±3	2~3												
静电容量变化率 Capacitance change	±15% 以内																	
品质因子 (Q值) Q D.F.	SL : Q : ≥ 50 (C ≥ 30pF) Q : ≥275+2.5C (C < 30pF) C : 静电容量Nominal Capacitance (pF) B,E(DF) : 2.5% max. F(DF) : 7.5% max.																	
I.R.	≥3000 MΩ																	
	绝缘强度 Dielectric strength	参见项目4. Pass the item No.4.																
14	外观 Appearance	无破缺,开裂等异常 No marked defect.	<table border="1" data-bbox="922 891 1474 1088"> <tbody> <tr> <td>温度 Templ</td> <td>40±2°C</td> </tr> <tr> <td>湿度 humidity</td> <td>90~95%RH</td> </tr> <tr> <td>时间 Time</td> <td>500±12h</td> </tr> </tbody> </table> 在室内环境放置24±2h再进行测量。 Let sit for 24±2 h at *room condition, then measure. <ul style="list-style-type: none"> •B,E,F温度特性的预处理: 电容器应储存在150 + 0/-10°C 1 h, 施加AC4000V 60s 的电压, 然后放在室内条件24±2 h, 再进行初步测量。 •Pretreatment for B,E,F char:Capacitor should be stored at 150+0/-10°C for 1 h, and apply the AC4000V(r.m.s.) 60s then placed at *room condition for 24±2 h before initial measurements. 	温度 Templ	40±2°C	湿度 humidity	90~95%RH	时间 Time	500±12h									
	温度 Templ	40±2°C																
	湿度 humidity	90~95%RH																
	时间 Time	500±12h																
静电容量变化率 Capacitance change	±20%以内 Within ±20%																	
品质因子 (Q值) Q D.F.	SL : Q : ≥ 350 (C ≥ 30pF) Q : ≥275+2.5C (C < 30pF) C : 静电容量 Nominal Capacitance(pF) B,E:5.0%max. F(DF) : 7.5% max.																	
I.R.	≥3000 MΩ																	
	绝缘强度 Dielectric strength	参见项目4. Pass the item No.4.																
15	外观 Appearance	无破缺,开裂等异常 No marked defect.	<table border="1" data-bbox="922 1464 1474 1727"> <tbody> <tr> <td>温度 Templ</td> <td>40±2°C</td> </tr> <tr> <td>湿度 humidity</td> <td>90~95%RH</td> </tr> <tr> <td>时间 Time</td> <td>500±12h</td> </tr> <tr> <td>电压 Voltage</td> <td>额定电压 Rated voltage</td> </tr> </tbody> </table> 在室内环境放置24±2h再进行测量。 Let sit for 24±2 h at *room condition, then measure. <ul style="list-style-type: none"> •B,E,F温度特性的预处理: 电容器应储存在150 + 0/-10°C 1 h, 施加AC4000V 60s 的电压, 然后放在室内条件24±2 h, 再进行初步测量。 •Pretreatment for B,E,F char:Capacitor should be stored at 150+0/-10°C for 1 h, and apply the AC4000V(r.m.s.) 60s then placed at *room condition for 24±2 h before initial measurements. 	温度 Templ	40±2°C	湿度 humidity	90~95%RH	时间 Time	500±12h	电压 Voltage	额定电压 Rated voltage							
	温度 Templ	40±2°C																
	湿度 humidity	90~95%RH																
	时间 Time	500±12h																
电压 Voltage	额定电压 Rated voltage																	
静电容量变化率 Capacitance change	±20%以内 Within ±20%																	
品质因子 (Q值) Q D.F.	SL : Q : ≥ 350 (C ≥ 30pF) Q : ≥275+2.5C (C < 30pF) C : 静电容量Nominal Capacitance (pF) B,E:5.0%max. F(DF) : 7.5% max.																	
I.R.	≥3000 MΩ																	
	绝缘强度 Dielectric strength	参见项目4. Pass the item No.4.																

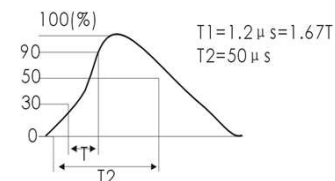
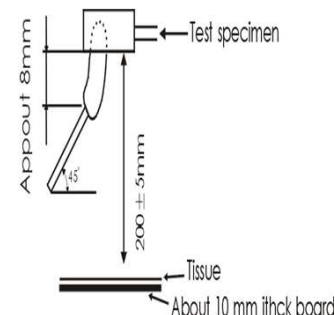
NO	项目Item	规格 Specification	测试方法 Test method								
16	持久性实验 Life	<table border="1"> <tr> <td data-bbox="240 293 400 421">外观 Appearance</td> <td data-bbox="400 293 727 421">无破缺,开裂等异常 No marked defect.</td> </tr> <tr> <td data-bbox="240 421 400 622">静电容量变化率 Capacitance change</td> <td data-bbox="400 421 727 622">±20%以内 Within ±20%</td> </tr> <tr> <td data-bbox="240 622 400 750">I.R.</td> <td data-bbox="400 622 727 750">≥3000 MΩ</td> </tr> <tr> <td data-bbox="240 750 400 1256">绝缘强度 Dielectric strength</td> <td data-bbox="400 750 727 1256">参见项目4. Pass the item No.4.</td> </tr> </table>	外观 Appearance	无破缺,开裂等异常 No marked defect.	静电容量变化率 Capacitance change	±20%以内 Within ±20%	I.R.	≥3000 MΩ	绝缘强度 Dielectric strength	参见项目4. Pass the item No.4.	<p>脉冲测试的执行. 每一个单独的电容器应该承受8kV脉冲(电压值为0到峰值)3次。 Impulse Voltage test is performed. Each individual capacitor shall be subjected to a 8kV Impulse (the voltage value means zero to peak) for 3 times.</p> <p>然后进行耐久性实验:将电容器放置实验箱内承受额定电压, 温度125±2℃,相对湿度50% max.时间1000小时.在室内条件下放置24±2h后进行测试 Then the capacitors are applied to life test:Apply voltage as Table for 1000 h at 125+2/-0℃, relative humidity 50% max.Remove and let sit for 24±2 h at *room condition, then measure.</p> <p>•B,E,F温度特性的预处理:电容器应储存在150 + 0/-10℃ 1 h, 施加AC4000V 60s 的电压, 然后放在室内条件24±2 h, 再进行初步测量。 •Pretreatment for B,E,F char:Capacitor should be stored at 150+0/-10° C for 1 h, and apply the AC4000V(r.m.s.) 60s then placed at *room condition for 24±2 h before initial measurements.</p> <p>施加 AC550V(r.m.s.)电压, 每隔1小时将电压升高到1000V,时间间隔0.1秒。 Applied voltage:AC550V(r.m.s.), except that once each hour the voltage is increased to AC1000V(r.m.s.) for 0.1s.</p> <div style="text-align: center;">  <p>(T1) = 1.2µs=1.67T Time to half-value (T2) = 50µs</p> <p>T1=1.2µs=1.67T T2=50µs</p> </div>
外观 Appearance	无破缺,开裂等异常 No marked defect.										
静电容量变化率 Capacitance change	±20%以内 Within ±20%										
I.R.	≥3000 MΩ										
绝缘强度 Dielectric strength	参见项目4. Pass the item No.4.										
17	引燃实验 Passive flammability	<p>燃烧的时间不能超过30s. 薄棉纸不被引燃 The burning time should not be exceeded the time 30s. The tissue paper should not ignite.</p>	<p>火焰长度 :12±1mm Length of flame :12±1mm</p> <p>瓦斯燃烧器 :最小长度35mm,内径:0.5±0.1mm,外径:0.9mm max Gas burner :Length 35mm min,Inside dia:0.5±0.1mm,Outside dia:0.9mm max</p> <p>瓦斯:丁烷瓦斯,最小纯度95%. Gas:Butane gas purity 95% min</p> <p>接受测试的电容器要保持在最有助于燃烧的火焰处,每个样品只能在火焰中暴露1次时间30秒。 The capacitor under test shall be held in the flame in the position which best promotes burning. Each specimen shall only be exposed once to the flame. Time of exposure to flame : 30 s.</p> <div style="text-align: center;">  </div>								

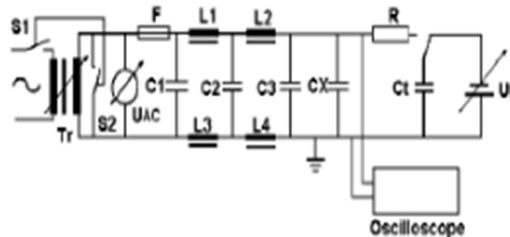
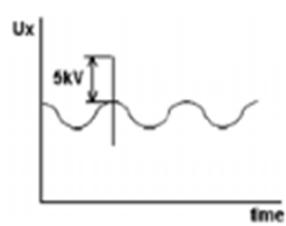
NO	项目 Item	规格 Specification	测试方法 Test method
18	耐燃性实验 Active flammability	缠绕在电容器上的纱布无燃烧,电测量不要求。 The cheese-cloth should not be on fire.	<p>在电容器本体上,包裹一层纯棉薄纱布.但不能超过两层.每个样本应承受一个储能电容器放电20次.如图依规定充电电压Vdc施加.每两次放电时间间隔5秒.整个测试过程中,施加Vac:250V 60(50)Hz,同时在最后一次放电结束后,应该持续保持2分钟,除非线因保险丝烧断呈开路。</p> <p>The capacitor shall be individually wrapped in at least one but more than two complete layers of cheesecloth.The capacitor shall be subjected to 20 discharges.The interval between successive discharges shall be 5 s.The UAC shall be maintained for 2 min after the last discharge.</p>  <p>Vac:Ur±5% Ur:额定电压 Rated Voltage C1,C2:滤波用电容器1u F±10% Filter capacitor1uF±10%, L1~L4:阻流线圈1.5mH±20%,16A 1.5mH±20%,16A Rod core choke C3:电容器0.033u F±5%,10KV Capacitor0.033uF±5%,10KV Cx:待测电容器 Capacitor specimens Ct:充电用电容器3uF±5%,10KV Charging capacitor 3uF ± 5%, 10KV R:100Ω±2% F:保险丝,额定电流16A Fuse, rated 16A Ut :Voltage impressed on the tank capacitor Ct</p> 

室内指温度15~35℃,湿度45~75%RH,大气压86~106千帕.

Indoor temperature refers to 15~35 °C, humidity 45~75% RH, atmospheric pressure 86~106 kPa

8. 测试方法的补充 Complement of Test Method

8.1、测试夹具 Test Jig

测试夹具应该是“规格和测试方法”中描述的A。

The test jig should be Jig A as described in “Specifications and Test methods”.

试样应按下面所述的条件焊接。

The specimen should be soldered by the conditions as described below.

焊接方法:回流焊。

Soldering Method : Reflow soldering

焊接: sn-3.0Ag-0.5Cu

Solder : Sn-3.0Ag-0.5Cu

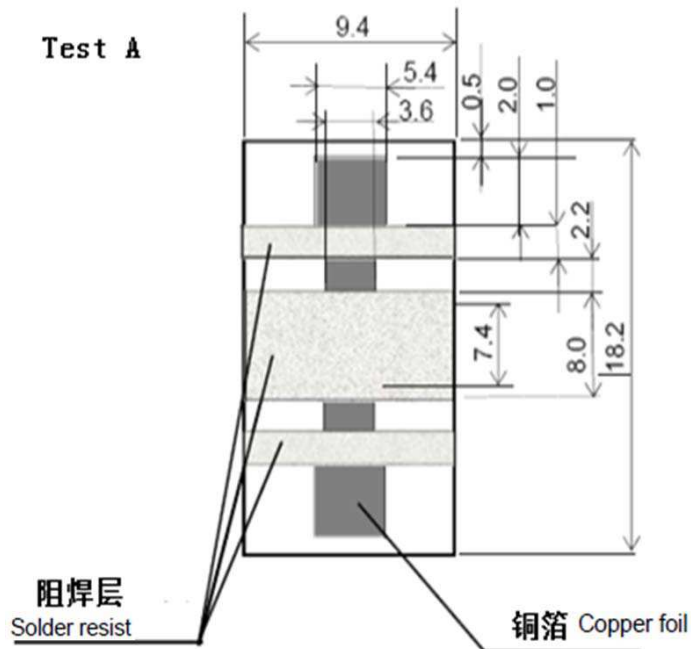

材料：玻璃环氧板

厚度：1.6mm

铜箔厚度：0.035mm

- Material : Glass Epoxy Board
- Thickness : 1.6mm
- Thickness of copper foil : 0.035mm

9. 包装 Packing

9.1. 编带的尺寸 Dimension of tape

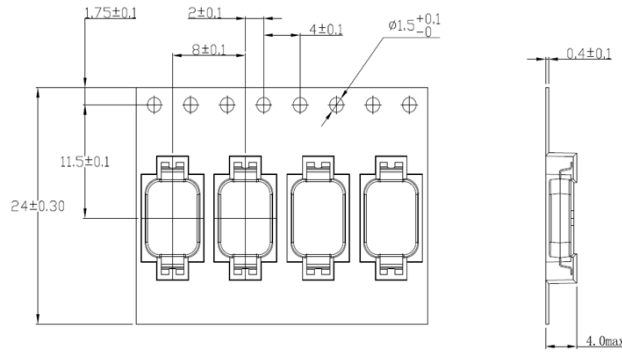

9.2. 滚动条的尺寸 Dimension of Reel

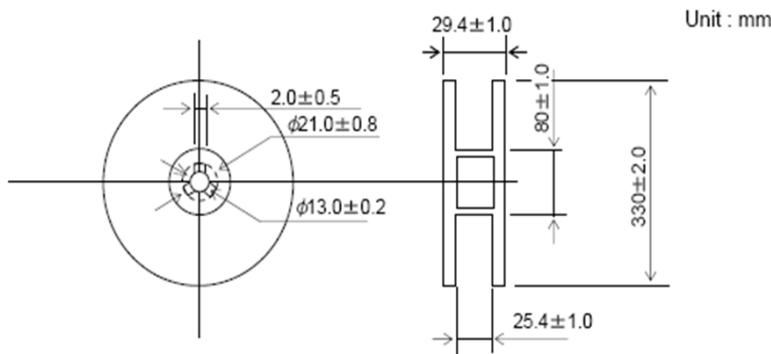

(1) 部分导线和部分留空的纸带应附在编带的结尾，如下所示：

Part of the leader and part of the empty tape shall be attached to the end of the tape as follows.

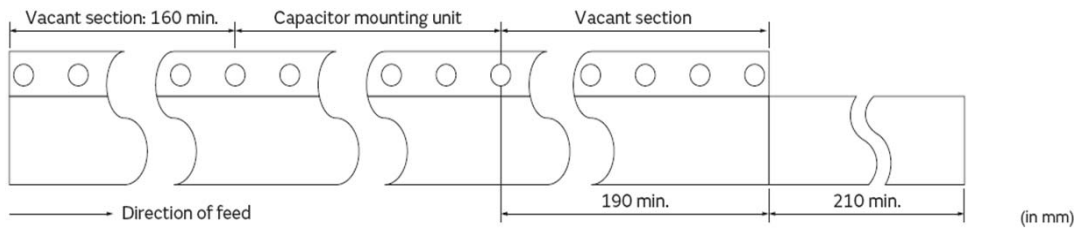

(2) 顶部胶带或覆盖带和基带不在胶带末端附着至少2个节距。

The top tape or cover tape and base tape are not attached at the end of the tape for a minimum of 2 pitches.

(3) 每卷短装数应在0.1%或者1pcs以内，以较大值为基准，短装位置不可连续。

Missing capacitors number within 0.1% of the number per reel or 1pc, whichever is greater, and not continuous

(4) 顶部胶带或覆盖胶带和底部胶带不得突出超出胶带边缘，不得覆盖链轮孔。

The top tape or cover tape and bottom tape shall not protrude beyond the edges of the tape and shall not cover sprocket holes.

(5) 链轮孔的累积公差，10个节距：±0.3mm。

Cumulative tolerance of sprocket holes, 10 pitches : ±0.3mm.

(6) 剥离力：在下面显示的方向上为0.1~0.6N。

Peeling off force : 0.1 to 0.6N in the direction shown on the follows.

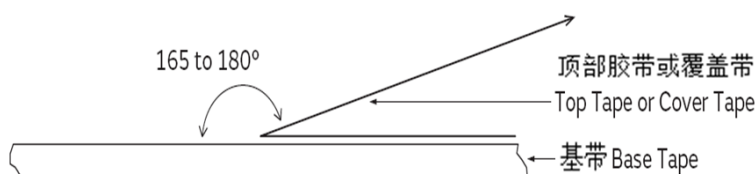

10. 标签范例 Label Example

例:

EX

管理代码
Management Code

规格 specifications

批号 lot number

客户料号
Customer Item Number

数量 quantity

环保标示
Environmental labeling

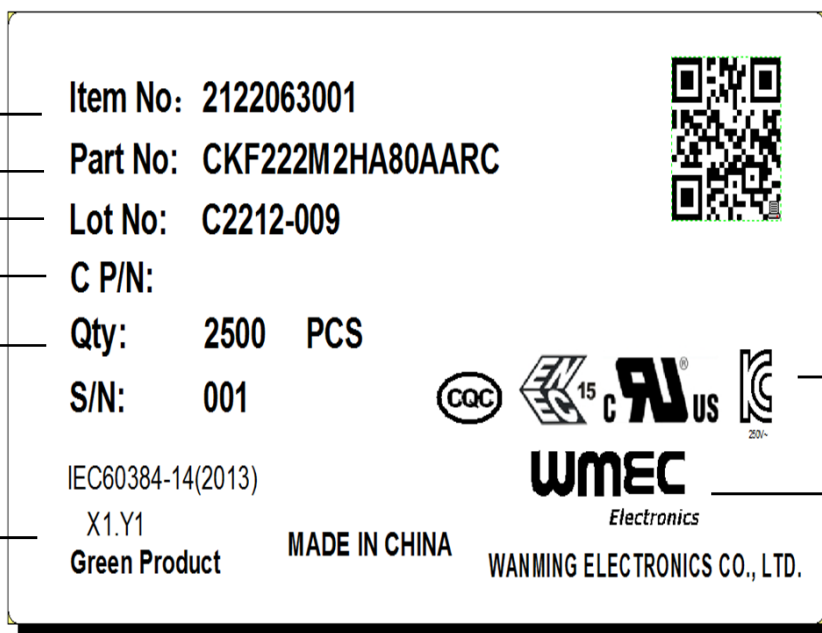

安规标示
Safety regulation label

商标
Trademark

11. 产品构造 Product structure

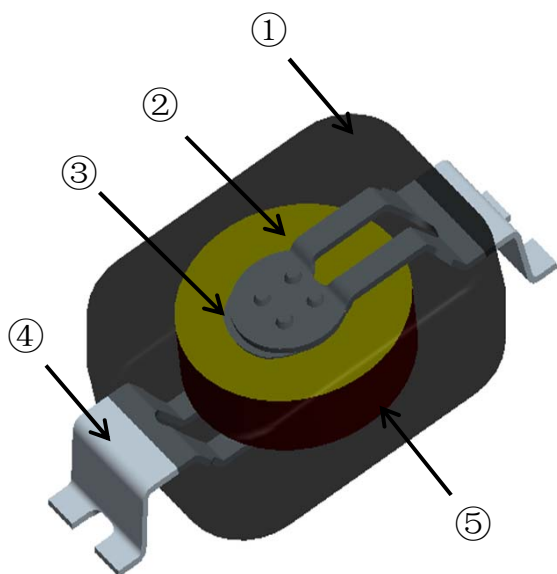

标记 Tab	部件名称 Component Name	物质成分 Material composition
①	包封层 Mold compound	环氧树脂 epoxy resin
②	电极 Electrode	Ag/Cu
③	焊锡 Solder	Sn-Pb-Ag
④	导线 Lead wire	Cu-Sn
⑤	瓷体 Ceramic medium	BaTiO3/其它 other

12. 生产工厂 Production plant

生产公司 Production company	厦门万明电子有限公司 XIAMEN WANMING ELECTRONICS CO., LTD
地址 Address	中国. 厦门市集美区白虎岩路88号 No 88 BaiHuYan Road JiMei District XiaMen, FuJian, China
联系电话 Contact number	0592-6771888

13. 修定事项说明 Description of revised items

1. 如有相关材料, 制品及制造工厂变更, 我们将及时通知您。

We will promptly notify you of any changes to relevant materials, products, or manufacturing plants.

2. 请在标准使用条件下使用, 如有超出使用条件造成损坏, 我司不承擔責任。

Please use it under standard conditions of use. Our company will not be responsible for any damage caused by exceeding the conditions of use.

3. 如有不详及建议之处, 请及时与我们联系, 我们将提供解答说明。

If you have any questions or suggestions, please do not hesitate to contact us and we will provide explanations.

1. 工作电压 OPERATING VOLTAGE

当DC-额定电容器用于交流或纹波电流电路时，一定要保持应用电压的 V_{p-p} 值或在额定电压范围内包含直流偏置的 v_{op-p} 值。当电压开始应用于电路或停止应用时，由于谐振或切换，可能会产生不正常的电压。确保在额定电压下使用电容器，其中包含不规则电压。

When DC-rated capacitors are to be used in AC or ripple current circuits, be sure to maintain the V_{p-p} value of the applied voltage or the V_{o-p} which contains DC bias within the rated voltage range. When the voltage is started to apply to the circuit or it is stopped applying, the irregular voltage may be generated for a transit period because of resonance or switching. Be sure to use a capacitor within rated voltage containing these irregular voltage.

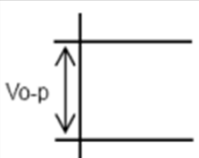
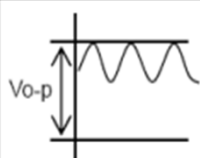
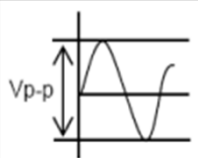
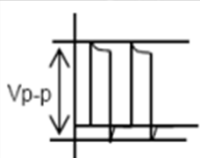
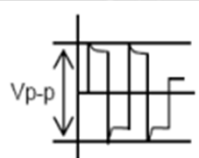
Voltage	DC Voltage	DC+AC Voltage	AC Voltage	Pulse Voltage(1)	Pulse Voltage(2)
Positional Measurement					

2. 工作温度与自生热 OPERATING TEMPERATURE AND SELF-GENERATED HEAT

保持电容器的表面温度低于额定工作温度范围的上限。一定要考虑到电容器本身产生的热量。当电容器用于高频电流、脉冲电流等时，由于电介质损耗，可能会产生自生热。在周围 25°C 环境下，外加电压应确保电容器自我产生的热量在 20°C 之内；当使用 0.1mmK 型热电偶测量时，电容器不应受其他元件热辐射和来自周围环境风的影响，过热可能导致电容器的温度特性可靠性降低。（切勿在冷却风扇运行时进行测量。否则，无法确保精确测量。）

Keep the surface temperature of a capacitor below the upper limit of its rated operating temperature range. Be sure to take into account the heat generated by the capacitor itself. When the capacitor is used in a high-frequency current, pulse current or the like, it may have the self-generated heat due to dielectric-loss. Applied voltage should be the load such as self-generated heat is within 20°C on the condition of atmosphere temperature 25°C . When measuring, use a thermocouple of small thermal capacity-K of $\varnothing 0.1\text{mm}$ and be in the condition where capacitor is not affected by radiant heat of other components and wind of surroundings. Excessive heat may lead to deterioration of the capacitor's characteristics and reliability. (Never attempt to perform measurement with the cooling fan running. Otherwise, accurate measurement cannot be ensured.)

3. 耐压测试条件 EST CONDITION FOR WITHSTANDING VOLTAGE

(1) AC的测试设备 TEST EQUIPMENT Test equipment for AC

测试设备的AC波形为 $50/60\text{Hz}$ 正弦波或者类似波形，如果失真的正弦波或超载的波形，则可能造成失效。

withstanding voltage should be used with the performance of the wave similar to $50/60\text{Hz}$ sine wave. If the distorted sine wave or over load exceeding the specified voltage value is applied, the defective may be caused.

(2) 电压应用方法

当施加耐压时，电容器的导线或端子应牢固地连接到输出端，然后电压应从接近零提高到测试电压。如果测试电压没有从零附近升高电压将直接施加到电容器上，测试电压应采用零交叉。测试结束时，应降低测试电压接近零，然后电容器的引线或端子应该从耐压试验的输出中取出。如果测试电压没有从零附近升高电压将直接施加到电容器，电压可能上升，因此可能会引起失效。

When the withstanding voltage is applied, capacitor's lead or terminal should be firmly connected to the out-put of the withstanding voltage test equipment, and then the voltage should be raised from near zero to the test voltage. If the test voltage without the raise from near zero voltage would be applied directly to capacitor, test voltage should be applied with the *zero cross. At the end of the test time, the test voltage should be reduced to near zero, and then capacitor's lead or terminal should be taken off the out-put of the withstanding voltage test equipment. If the test voltage without the raise from near zero voltage would be applied directly to capacitor, the surge voltage may arise, and therefore, the defective may be caused.

注：零交叉是电压正弦波通过 0V 的点，如下图所示：

Note: zero crossing is the point where the voltage sine wave passes through 0V , as shown in the figure below:

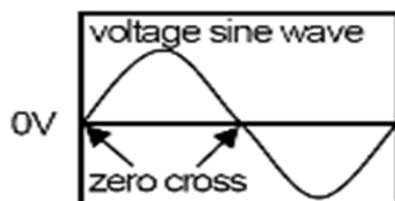

4. 自动防故障装置 FAIL-SAFE When

当电容器被破坏时，故障可能导致短路，从而可能导致电击、火灾等事故发生，为此一定要提供一个类似保险丝一样的安全装置。

Capacitor would be broken, failure may result in a short circuit. Be sure to provide an appropriate fail-safe function like a fuse on your product if failure would follow an electric shock, fire or fume.

5. 振动与冲击 VIBRATION AND IMPACT

在使用过程中，不要过度震动或冲击电容器。

Do not expose a capacitor or its leads to excessive shock or vibration during use.

6. 焊接 SOLDERING

6-1 回流焊接 Reflow Soldering

当焊接电容器时，应在下列条件下进行：

When soldering capacitor, it should be performed in following conditions:

焊接温度 Soldering temperature: 230 ~ 260°C

焊接时间 Soldering time : 10 ~ 30s

预热温度 Preheating temperature : 170°C max.

6-2 波峰焊接 Soldering Iron

应在以下条件焊接电容器：

The capacitor shall be welded under the following conditions:

焊接温度 Soldering temperature: 260°C max

焊接时间 Soldering time: 5s max

预热温度 Preheating temperature : 120°C max.

预热时间 Preheating time: 60s max

6-3 烙铁

当将此产品焊接到PCB/PWB时，不要超过电容器的焊接热阻规格。使该产品过度加热会使内部结焊料熔化，并可能导致热冲击，从而破坏陶瓷组件

When soldering this product to a PCB/PWB, do not exceed the solder heat resistance specification of the capacitor. Subjecting this product to excessive heating could melt the internal junction solder and may result in thermal shocks that can crack the ceramic element.

当用烙铁焊接电容器时，应在下列条件下进行。

When soldering capacitor with a soldering iron, it should be performed in following conditions.

焊接温度 Temperature of iron-tip : 400°C max.

接功率 Soldering iron wattage : 50W max.

焊接时间 Soldering time : 3.5s max.

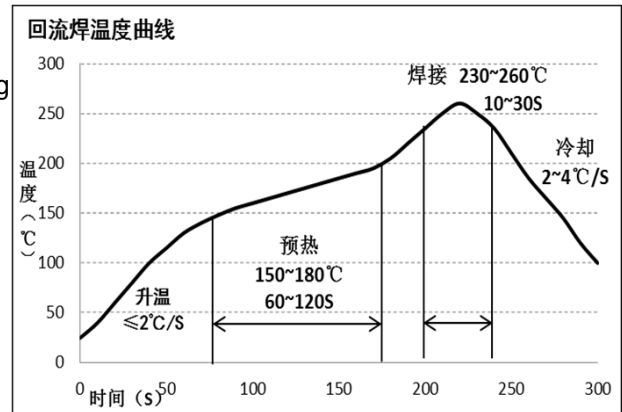

7. 粘结、树脂成型和涂层 BONDING, RESIN MOLDING AND COATING

在粘合、成型或涂覆该产品之前，通过测试粘结的、模压的或涂覆的产品在预期设备中的性能来验证这些工艺不会影响电容器的质量。在工艺中，含有有机溶剂的树脂（乙酸乙酯、甲乙酮、甲苯等）是不合适的，电容器的外涂层树脂可能被有机溶剂破坏，可能导致短路风险。

胶粘剂、成型树脂或涂层的厚度变化可能引起电容器外涂层树脂开裂或者陶瓷元件在温度循环中开裂。

Before bonding, molding or coating this product, verify that these processes do not affect the quality of capacitor by testing the performance of the bonded, molded or coated product in the intended equipment. In case of the amount of applications, dryness / hardening conditions of adhesives and molding resins containing organic solvents (ethyl acetate, methyl ethyl ketone, toluene, etc.) are unsuitable, the outer coating resin of a capacitor is damaged by the organic solvents and it may result, worst case, in a short circuit.

The variation in thickness of adhesive, molding resin or coating may cause a outer coating resin cracking and/or ceramic element cracking of a capacitor in a temperature cycling.

8. 操作及储存环境 OPERATING AND STORAGE ENVIRONMENT

电容器的绝缘涂层不能形成完全的密封，因此，不要在腐蚀性的空气或使用或储存电容器，特别是在氯化物气体、硫化物气体、酸、碱、盐或类似物的情况下，避免暴露于湿气中。在清洁、粘接或成型此产品之前，请先在指定设备上测试经清洗、接合或模塑的产品性能，以确保上述工序不会影响电容器的质量。

The insulation coating of capacitors does not form a perfect seal; therefore, do not use or store capacitors in a corrosive atmosphere, especially where chloride gas, sulfide gas, acid, alkali, salt or the like are present. And avoid exposure to moisture. Before cleaning, bonding, or molding this product, verify that these processes do not affect product quality by testing the performance of a cleaned, bonded or molded product in the intended equipment.

本产品属于MSL 1级。

This one is MSL 1 product.

电容器存放条件，温度：10 至 30℃； 湿度：60% max.

Store the capacitors in the following conditions at all times.

Temperature : 10 to 30℃

Humidity : 60% max.

9. 应用的限制 LIMITATION OF APPLICATIONS

请在使用我们的产品前与我们联系，在以下所列的应用程序中，需要特别高的可靠性，以防止可能直接对第三方的生命、身体或财产造成损害的缺陷。

Please contact us before using our products. In the applications listed below, special high reliability is required to prevent defects that may directly damage the life, body or property of third parties.

- 1、飞机设备 Aircraft equipment
- 2、航空航天设备 Aerospace equipment
- 3、海底设备 Subsea equipment
- 4、电站控制设备 Power station control equipment
- 5、医疗设备 Medical equipment
- 6、运输设备(汽车、火车、轮船等) Transportation equipment (car, train, ship, etc.)
- 7、交通信号设备 Traffic signal equipment
- 8、防灾/预防犯罪设备 Disaster / crime prevention equipment
- 9、数据处理设备对公众的影响 The impact of data processing equipment on the public
- 10、将类似的复杂性和/或可靠性要求应用于上面列出的其它应用

Apply similar complexity and / or reliability requirements to other applications listed above

注意 NOTICE**1.清洗 (超声波清洗) Cleaning (ultrasonic cleaning)**

进行超声波清洗, 注意以下情况 For ultrasonic cleaning, pay attention to the following conditions:

清洗能力:每公升或少于20瓦的输出。Cleaning capacity: output of 20 watts per liter or less.

冲洗时间:5分钟。Washing time: 5 minutes.

不要直接振动PCB/PWB。Do not directly vibrate PCB / PWB.

过度的超声波清洗可能导致引线端子的疲劳破坏。Excessive ultrasonic cleaning may lead to fatigue failure of lead

2. 电容器的电容变化 Capacitance change of capacitor**1类电容器 Class 1 capacitors**

电容可能随周围温度或外加电压而变化。

Capacitance might change a little depending on a surrounding temperature or an applied voltage.

如果您使用严格的时间常数电路, 请与我们联系。

Please contact us if you use for the strict time constant circuit.

2类电容器 Class 2 capacitor

2类电容器, 如温度特性B、E、F等, 具有老化特性, 电容器在长时间内不工作, 电容值会有轻微地降低。此外, 根据周围的温度或施加的电压, 电容可能会发生很大的变化。因此, 它不太可能用于时间常数电路。

Class 2 capacitors, such as temperature characteristics B, e, F, etc., have aging characteristics. If the capacitor does not work for a long time, the capacitance value will be slightly reduced. In addition, the capacitance may vary greatly depending on the ambient temperature or applied voltage. Therefore, it is unlikely to be used in time constant circuits.

如果您想了解详细的信息, 请与我们联系。If you want more information, please contact us.

3.性能检验设备 PERFORMANCE CHECK BY EQUIPMENT

在使用电容器之前, 请检查设备的性能和规格是否有问题。

Before using a capacitor, check that there is no problem in the equipment's performance and the specifications.

一般来说, 2类陶瓷电容器在电容上具有电压依赖性特性和温度依赖性特性。因此, 电容值可能会根据设备的运行状况而变化。所以, 一定要确认电容器的电容值变化中的接收影响, 如泄漏电流和噪声抑制特性。

Generally speaking, Class 2 ceramic capacitors have voltage dependence characteristics and temperature dependence characteristics in capacitance. So, the capacitance value may change depending on the operating condition in a equipment. Therefore, be sure to confirm the apparatus performance of receiving influence in a capacitance value change of a capacitor, such as leakage current and noise suppression characteristic.

此外, 如果需要的话, 检查设备中电容器的防浪涌能力, 因为浪涌电压可能通过电路的电感超过特定值。

Moreover, check the surge-proof ability of a capacitor in the equipment, if needed, because the surge voltage may exceed specific value by the inductance of the circuit.

4. 空间尺寸 Land Dimensions

下面是回流焊接的推荐空间尺寸, 关于“a”尺寸, 是以确保适用于您的设备的安全标准所要求的爬电距离。

The recommendable land dimensions for reflow soldering are follows. Regarding the "a" dimension, to ensure the creepage distance required by the safety standard applies to your equipment*

尺寸Dimension	a	b	c
8.0x6.0	8.0	2.2	3.6

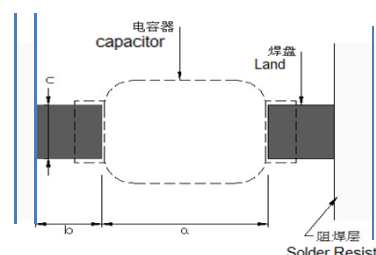
**5.芯片焊料 Chip solder**

为确保产品焊锡耐热性, 内部芯片焊接使用高温含铅锡膏。

In order to ensure the heat resistance of solder, high temperature lead solder paste is used for internal chip welding.

6.豁免条款 Exemptions

2010/571/EU 7(a): 高熔化温度型焊料中的铅 (即铅含量超过85%的铅基合金焊料)

Lead in high melting temperature solder (i.e., lead based alloy solder with a lead content exceeding 85%)

请注意 NOTE

1、请确保您的产品已被评估, 以确保您的规格和我们的产品相匹配。Please make sure that your product has been evaluated in view of your specifications with our product being mounted to your product.

2、请不要使用偏离我们规格的产品。You are requested not to use our product deviating from this specification.